

# ***LABEL FEEDER***

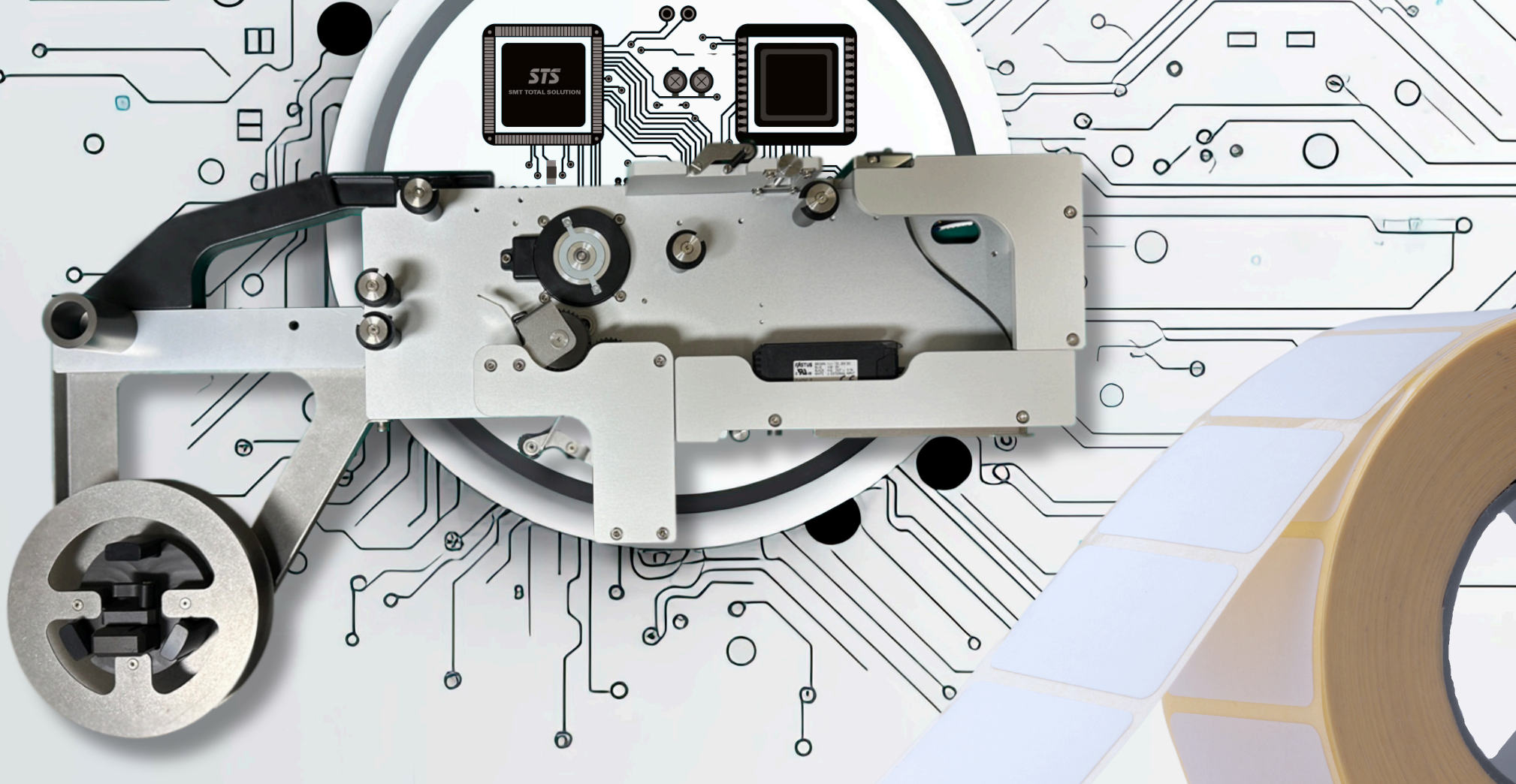

# LABEL FEEDER DEVELOPED BY STS

SMT TOTAL SOLUTION

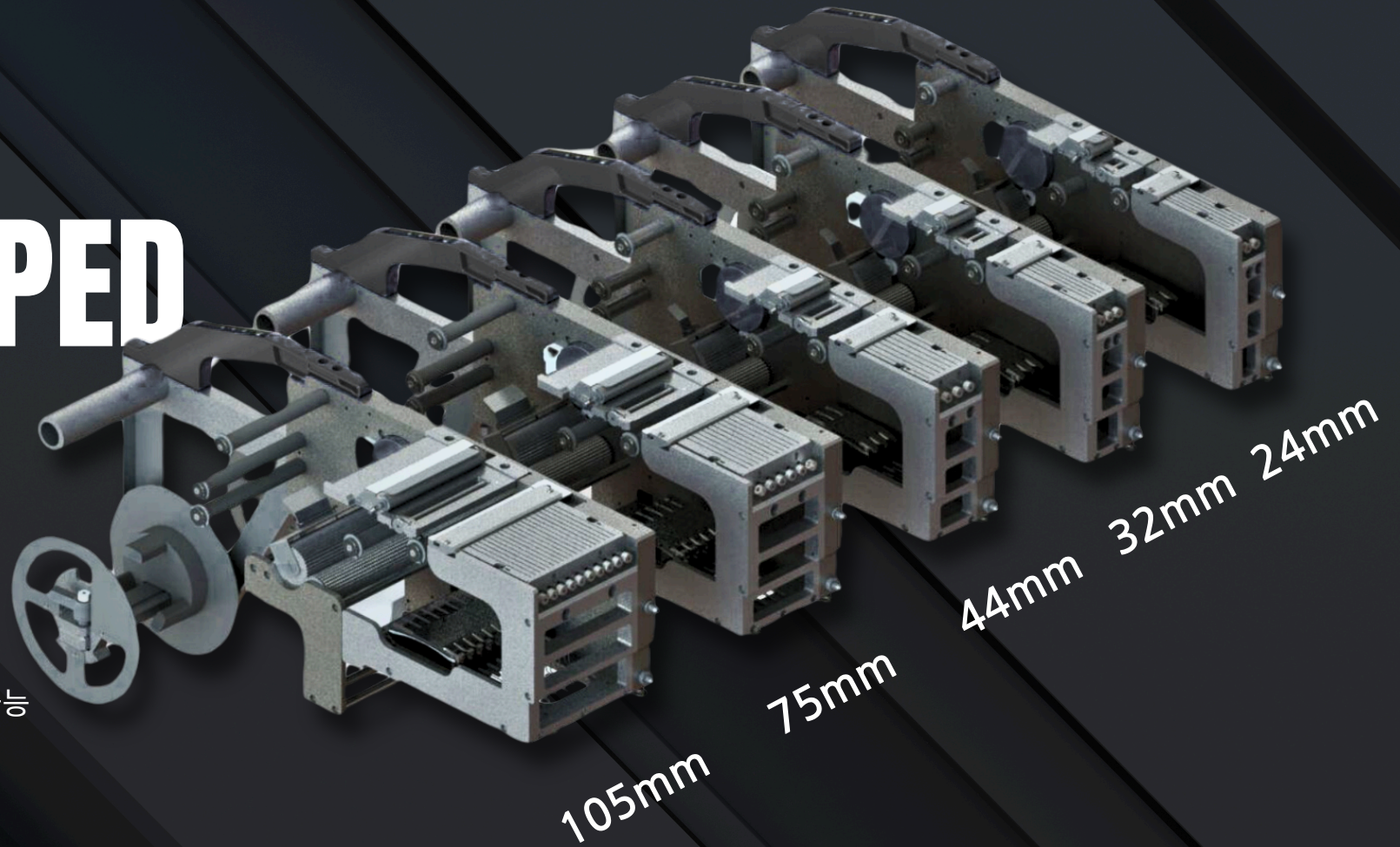

- ▷ TYPE : 24, 32, 44, 75, 105mm
- ▷ 속도 가변 (MODE 1 ~ 10단계) 가능
- ▷ 속도 최저 75ms ~ 최대 115ms
- ▷ 1mm 간격으로 전진
- ▷ 이형지 / 후방 배출
- ▷ 이송 피치 / 0 ~ 60.9mm
- ▷ 정도

X  $\pm 0.2\text{mm}$  ( $C_p \geq 1.0$ )

Y  $\pm 0.2\text{mm}$  ( $C_p \geq 1.0$ )

Z  $\pm 0.2\text{mm}$

Website [www.smt-sts.com](http://www.smt-sts.com)

Youtube [www.youtube.com/@smt-sts](http://www.youtube.com/@smt-sts)

# DEVICE FEATURES

★ 75mm 기준 5.5kg 이하 초경량

간단하고 편리한 사용

Control Button

Label Loading Assy

- Label Size 별로 Knob를 돌려 가변

Label Guide Assy

- 사용자재 Size에 맞게 Sensor 조정
- 라벨이 달라 붙지 않고 정착제가 남지 않는

Station Board

- Fiber 센서 사용

Label Reel hanger

- Label Size 별로 Knob를 돌려 가변
- 견고하고 편리한 사용

Film Ejector

- 원뿔형 기어 형상으로 안정된 배출

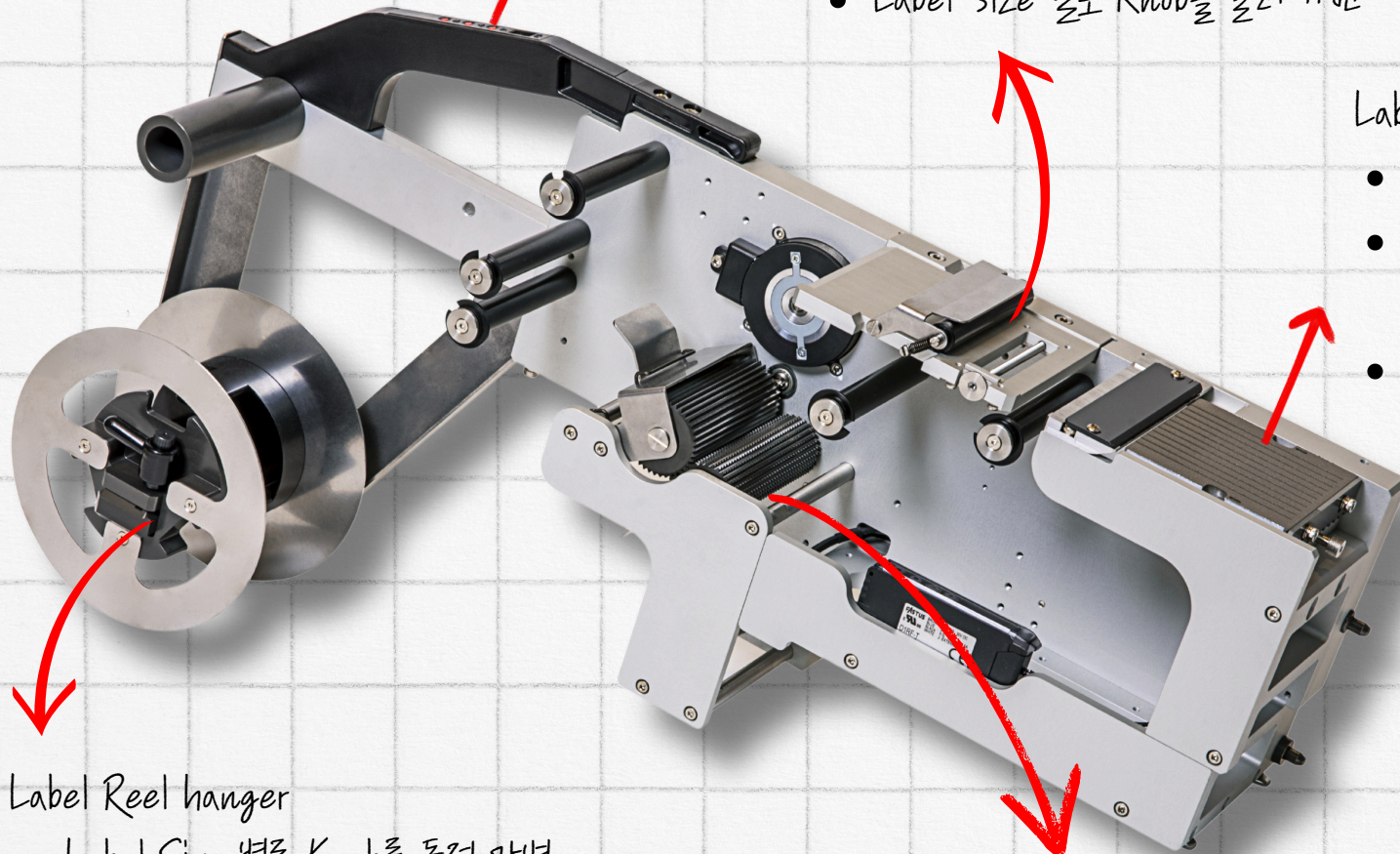
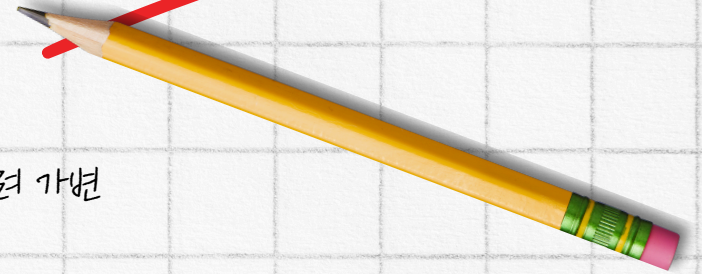

# KEY COMPONENT



CLEAN REMOVAL

# STATION BOARD

ACCOMMODATE VARIOUS LABELS

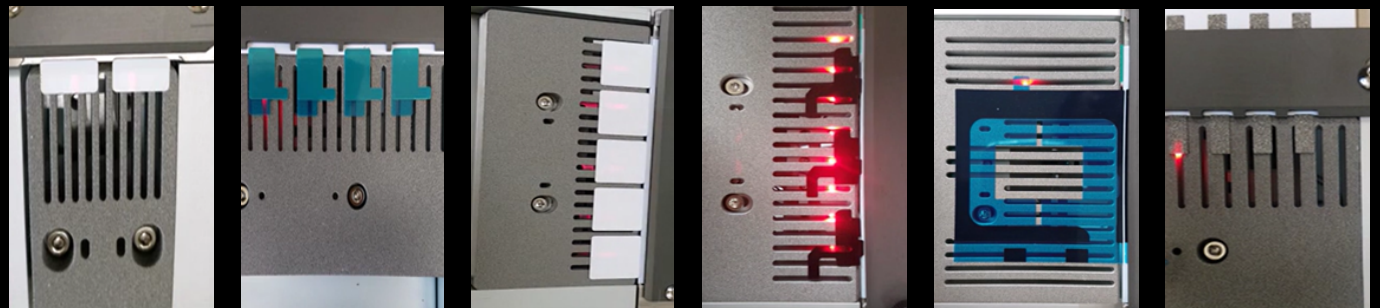
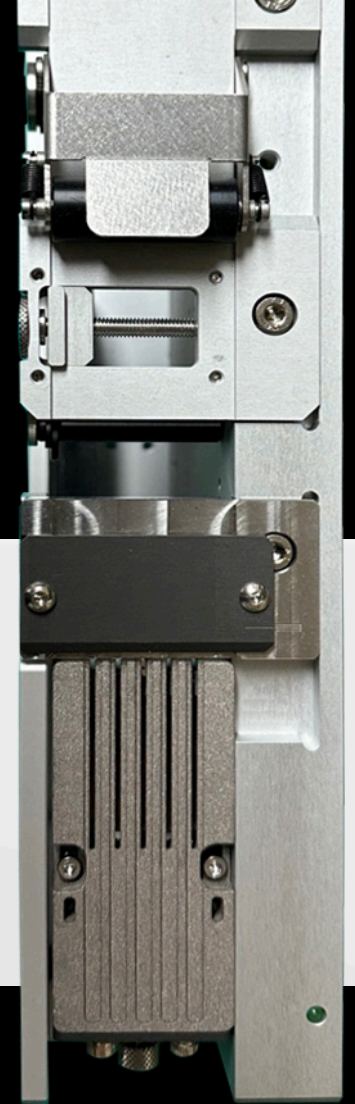

# INSERT IT BY SLIDING IT INTO THE FEEDER BASE

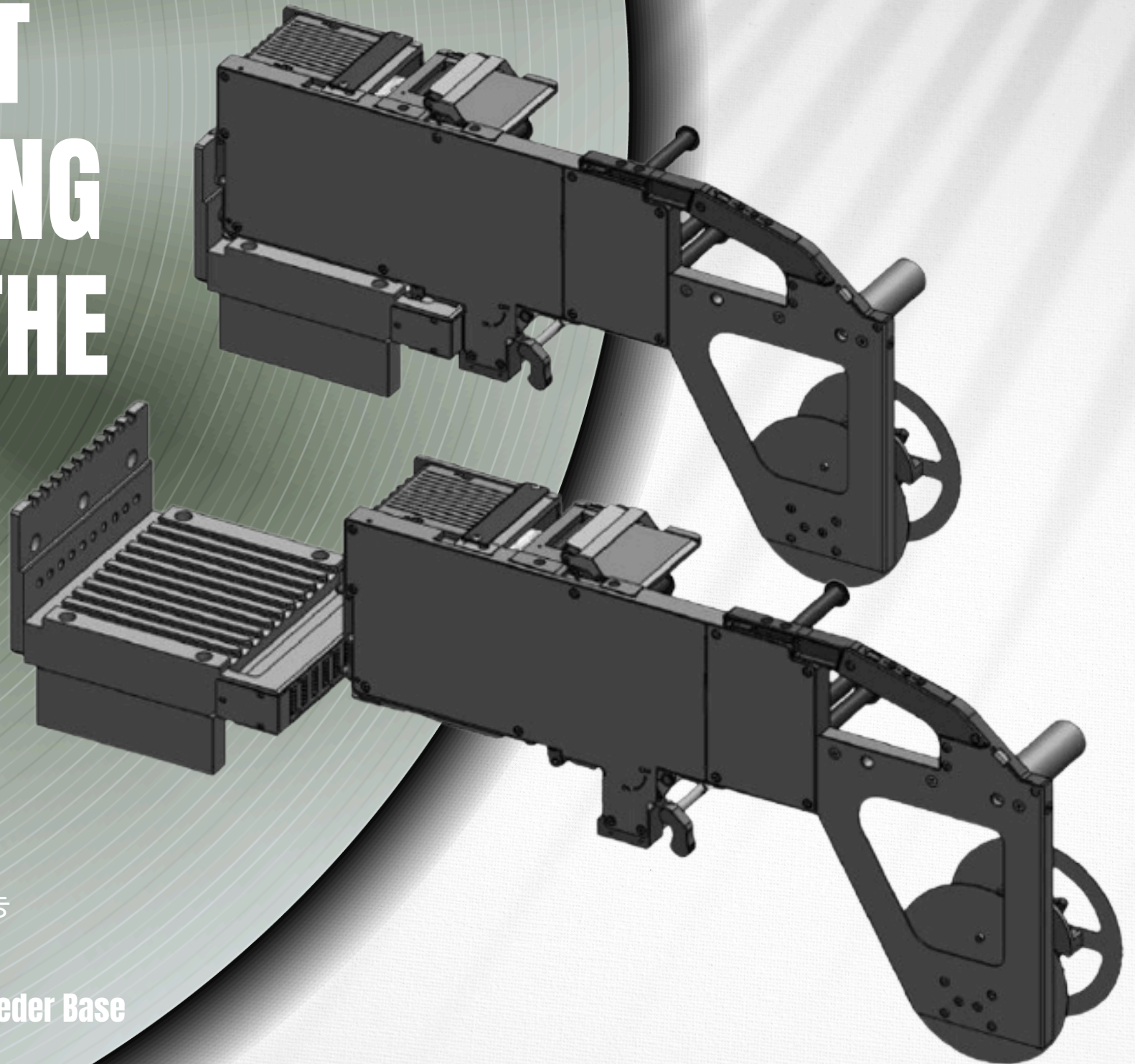

※ 피더베이스 별도 판매 가능

※ 참고 이미지

75 mm Feeder / 10 Slot Feeder Base

# 라벨 제작 시 주의사항

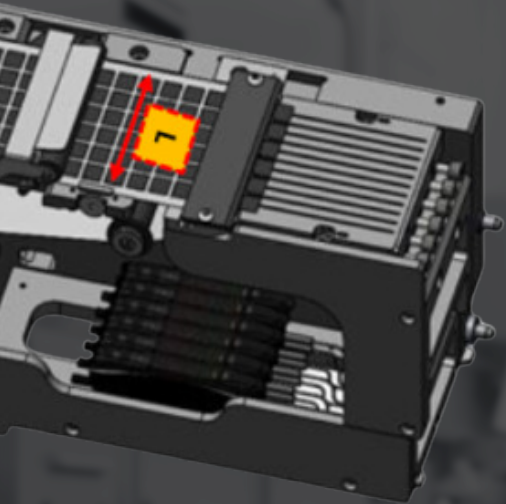

Feeder Type	X (mm)	Y (mm)	L (mm)	A (mm)	B (mm)	P (mm)	배열
24 (Min)	3	3	10	2	2	250	1열
24 (Max)	28	70	24	Free	Free	250	3열
32 (Min)	3	3	32	2	2	250	1열
32 (Max)	28	70	44	Free	Free	250	3열
44 (Min)	3	3	32	2	2	250	1열
44 (Max)	28	70	44	Free	Free	250	5열
75 (Min)	3	3	44	2	2	250	1열
75 (Max)	71	70	75	Free	Free	250	9열
105 (Min)	3	3	75	2	2	250	1열
105 (Max)	101	70	105	Free	Free	250	10열

